

These are the unpopulated DIP switches located above S1

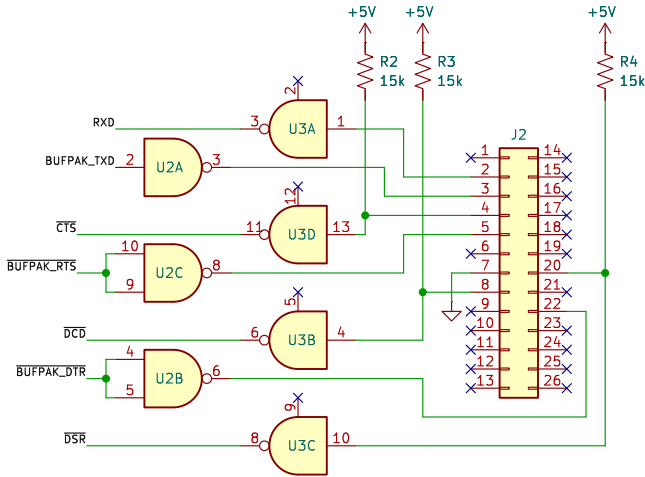

Cable pinout

color	J2 pin	DB25F pin
brown	1	1
red	2	2
orange	3	3
yellow	4	NC (jumpered to J2 pin 5)
yellow	5	NC (jumpered to J2 pin 4)
blue	7	7
purple	20	20
gray	22	6
white	12	19

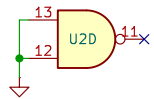
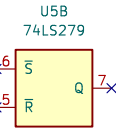
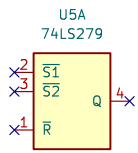
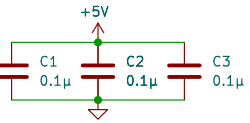
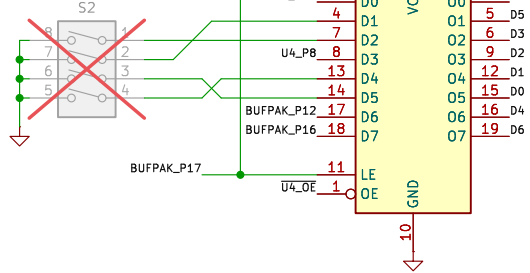
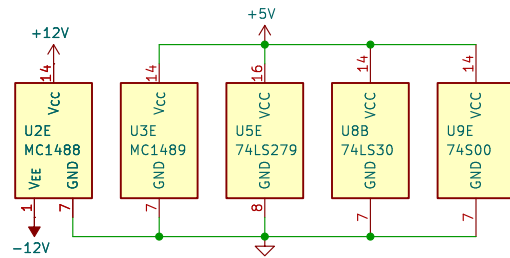

Apple II Serial Printer Card
by Orange Micro
captured by Mark Aikens

Sheet: /
File: Orange-Micro-Serial-Grappler.kicad_sch
Title: Orange Micro Serial Grappler
Size: USLegal Date: 2024-07-16
KiCad E.D.A. 8.0.1

Rev: A
Id: 1/1