

Port

File: port.kicad_sch

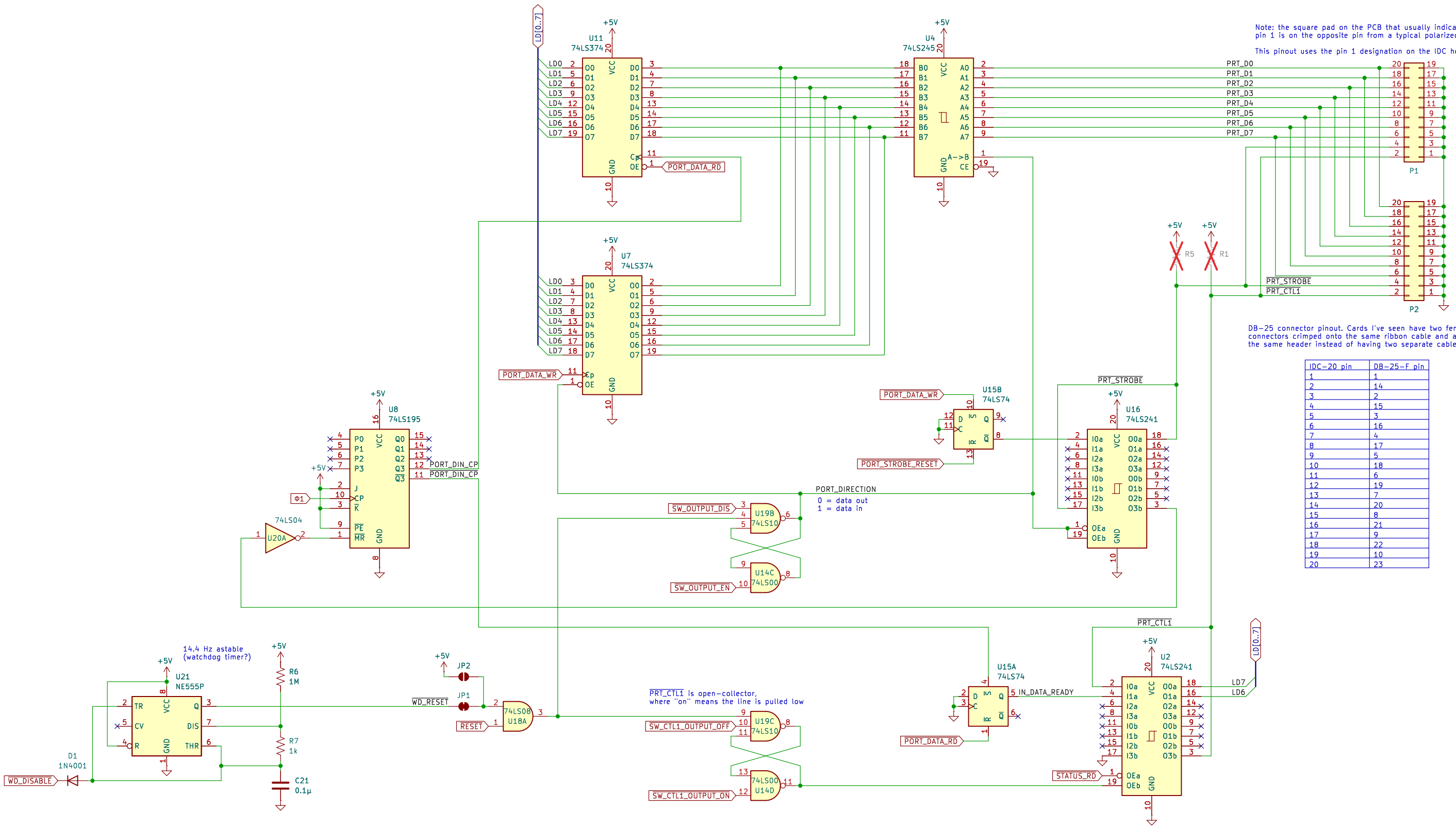

Note: the square pad on the PCB that usually indicates pin 1 is on the opposite pin from a typical polarized IDC connector. This pinout uses the pin 1 designation on the IDC header itself.

DB-25 connector pinout. Cards I've seen have two female DB-25 connectors crimped onto the same ribbon cable and attached to the same header instead of having two separate cable assemblies.

IDC-20 pin	DB-25-F pin
1	1
2	14
3	2
4	15
5	3
6	16
7	4
8	17
9	5
10	18
11	6
12	19
13	7
14	20
15	8
16	21
17	9
18	22
19	10
20	23