

Apple II networking card
by Digicard
captured by Mark Aikens

Sheet: /
File: Digicard-D-Net.kicad_sch

Title: Digicard D-Net

Size: USLetter Date: 2023-12-19
KiCad E.D.A. 8.0.1

Rev: 3
Id: 1/2

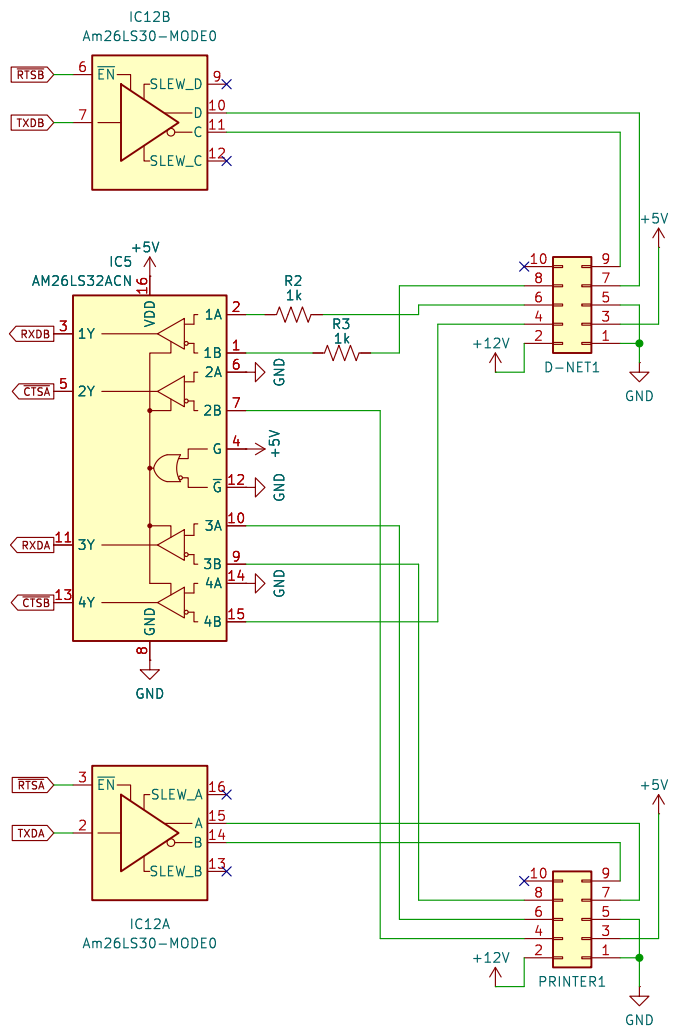

IDC-10 to DB-9 (female) ribbon cable

Pin	DB-9 (F) pin	signal
1	1	GND
2	6	+12V
3	2	+5V
4	7	CTS
5	3	GND
6	8	RX+
7	4	TX+
8	9	RX-
9	5	TX-
10	NC	

(matches a Macintosh DB-9 serial port pinout)

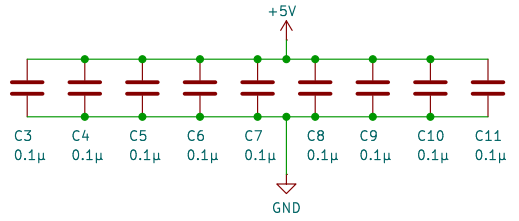
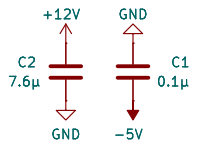
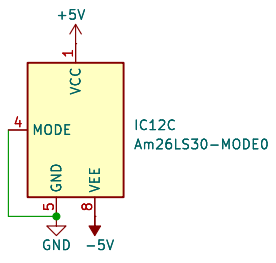

Apple II networking card
by Digicard
captured by Mark Aikens

Sheet: /Transceivers/
File: transceivers.kicad_sch

Title: Digicard D-Net

Size: USLetter Date: 2023-12-19
KiCad E.D.A. 8.0.1

Rev: 3
Id: 2/2